

Delta Transducers

Model : F2F



Features & Application

Universal material testing machine, hopper scale, hook scale, packaging scale, belt scale, pluginforce tester and other tension and pressure testing instruments as well as instruments as well as automation equipment and testing peld.

Mounting Dimension

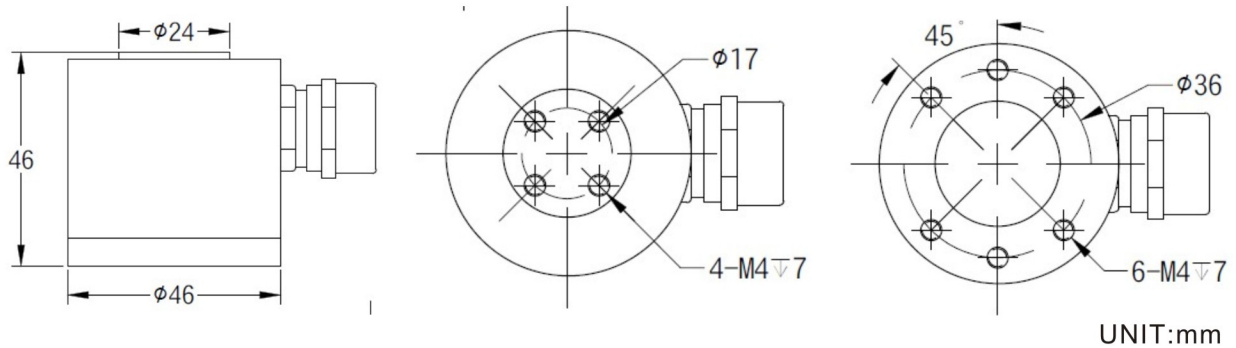

CAP(kg)	
X	5 / 10 / 20 / 50
Y	5 / 10 / 20 / 50
Z	5 / 10 / 20 / 50 / 100

Load Direction

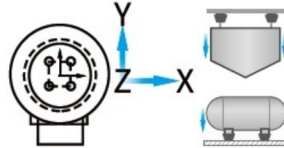

Wiring

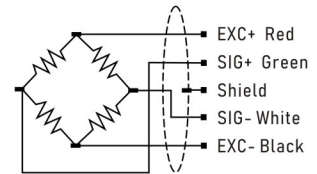

Technical Parameters

Specifications	Technique
Capacity	5、 10、 20、 30、 50、 100kg
Rated Output	1.0±10% mV/V
Zero Balance	±2%F.S.
Response Frequency	10kHz
Non-linearity	1.0% F.S.
Hysteresis	1.0% F.S.
Non-repeatability	1.0% F.S.
Creep (30min)	0.1% F.S.
Safe Overload	120%
Ultimate Overload	200%
Operating Temp.	-20~80°C
Temp. Shift Zero	0.05% F.S. / °C
Temp. Shift Span	0.05% F.S. / °C
Impedance	750Ω
Range Excitation	5~10V
Insulation Resistance	>5000MΩ / 100VDC
Cable	Ø6 X 3m