

## Model : ARI8-502

### Features & Application

Universal material testing machine, hopper scale, hook scale, packaging scale, belt scale, pluginforce tester and other tension and pressure testing instruments as well as instruments as well as automation equipment and testing peld.



### Mounting Dimension

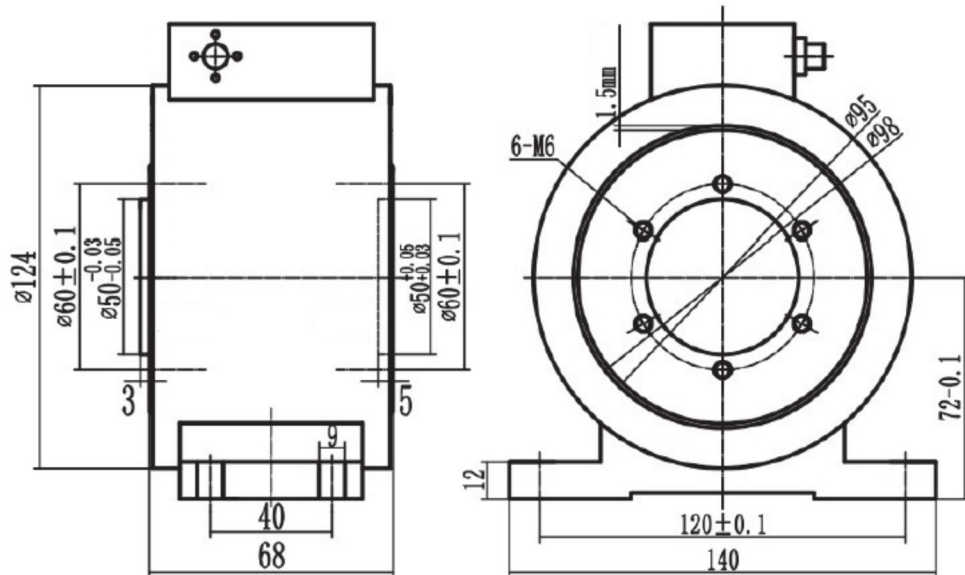

量程 (N. m) 5-50 UNIT:mm

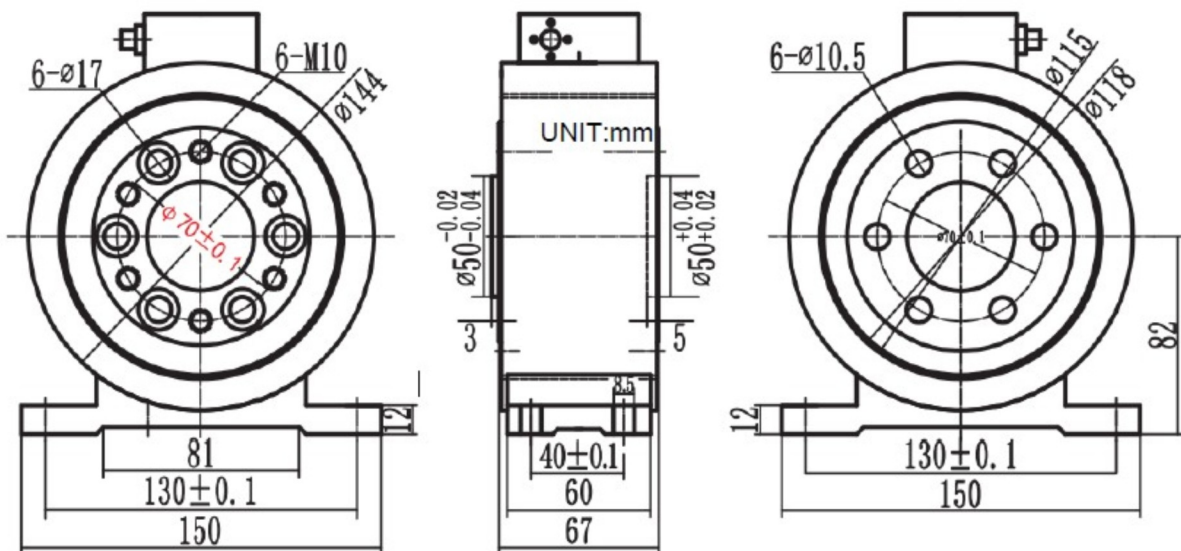

量程 (N. m) 50-500 UNIT:mm

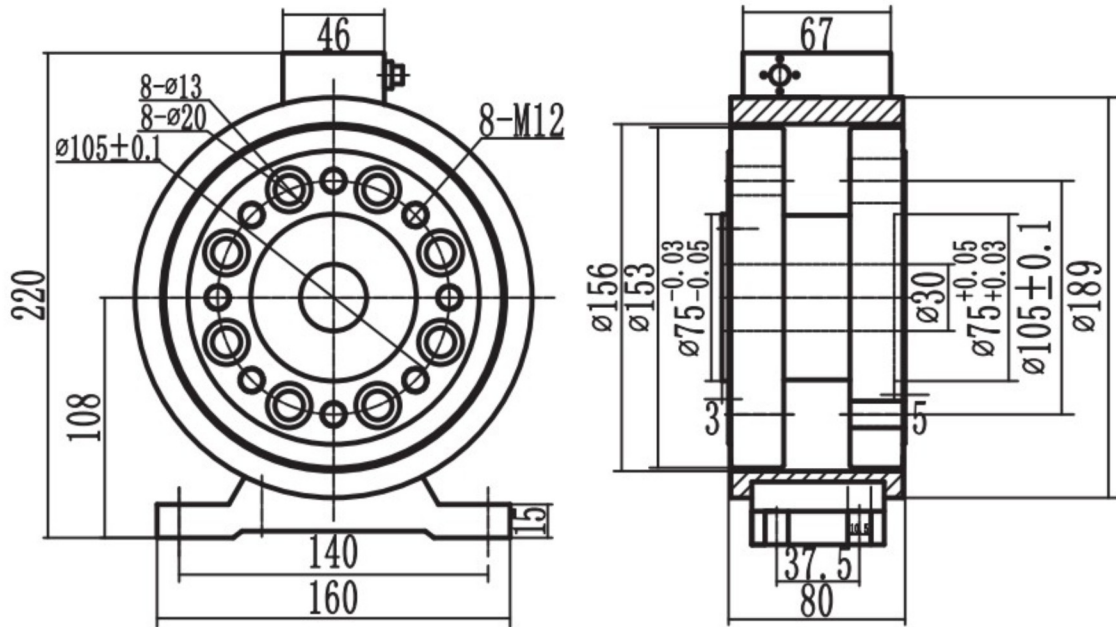

量程 (N.m) 1000-2000 UNIT:mm

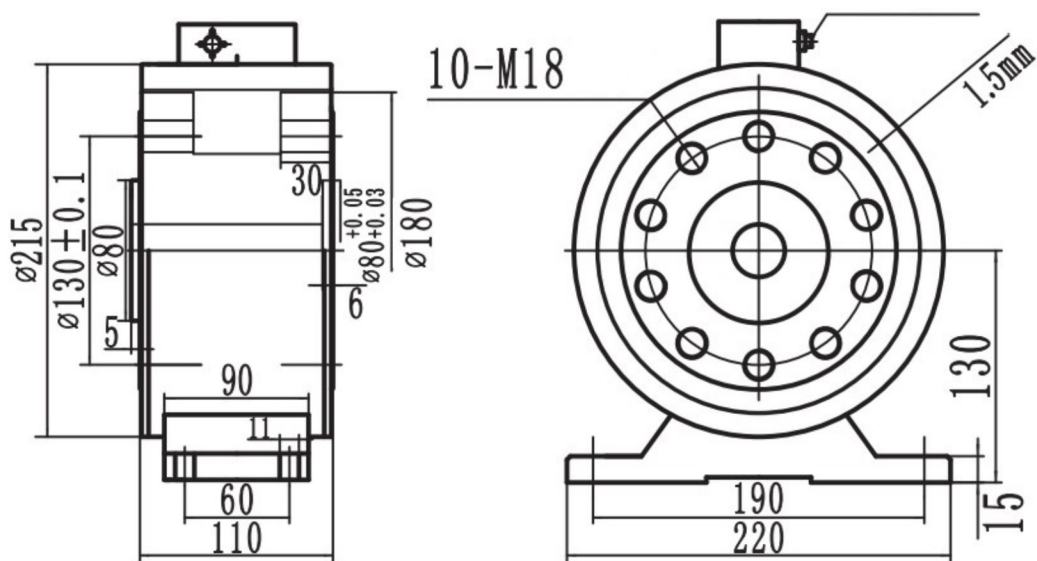

量程 (N.m) 5000-10000 UNIT:mm

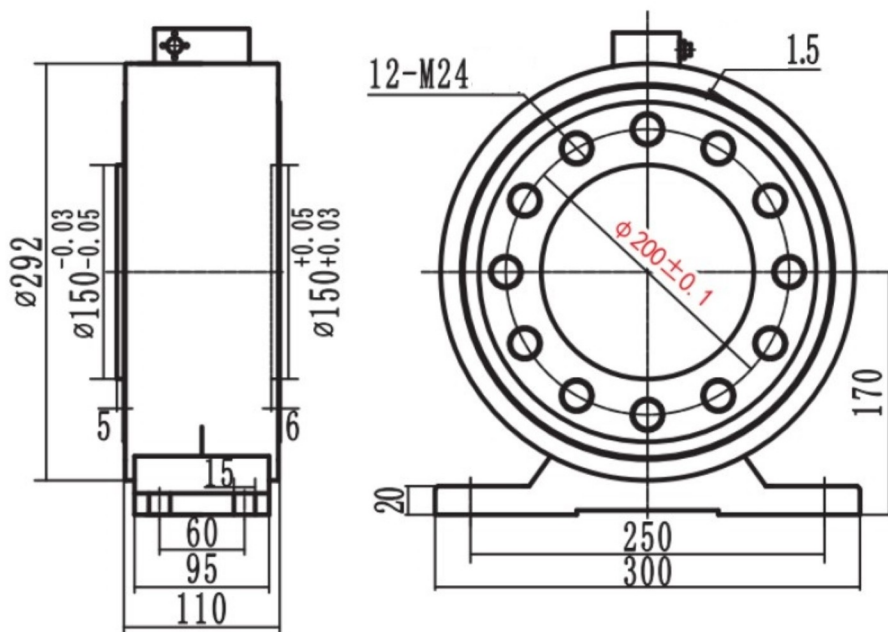

量程 (N.m) 30000-40000 UNIT:mm

#### Load Direction

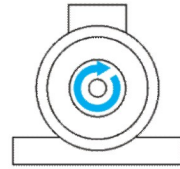

#### Wiring

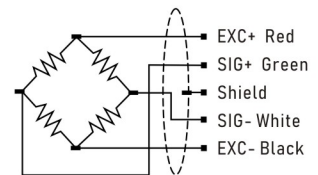

### Technical Parameters

Specifications	Technique
Capacity	5、50、500、1000、2000、5000、10000、30000、4000 N.m
Speed Signal	8000rpm
Speed Capacity	60 ( > 10000N.m : 180 )
Zero Balance	0.2%F.S.
Non-linearity	0.05% F.S.
Hysteresis	0.05% F.S.
Non-repeatability	0.05% F.S.
Creep (30min)	0.05% F.S.
Temp Effect On Output	0.05% F.S. / 10°C
Temp Effect On Zero	0.05% F.S. / 10°C
Response Frequency	10kHz
Load Resistance	≥5000MΩ / 100VDC
Working voltage	5~15V
Impdance	750Ω
Operating Temp.	-20~80°C
Safe Overload	120%
Maximum Overload	150%
Cable	Ø5 X 3m