

Delta Transducers

Model : ARI630D



Features & Application

Small size, simple and convenient installation, high precision and high dynamic frequency in one, main application: insertion force test, the rivet machine, welding machine, lamination machine, hot and cold pressure keyboard button feel degrees such as pull stress testing instruments, automation equipment, test area.

Mounting Dimension

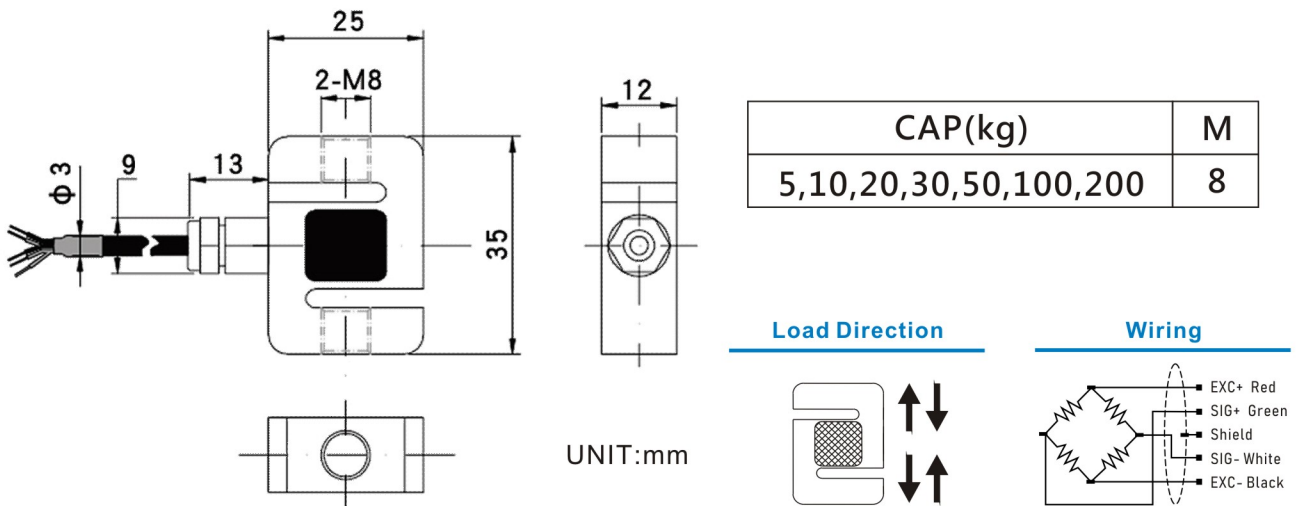

Technical Parameters

Specifications	Technique
Capacity	5、 10、 20、 30、 50、 100、 200 kg
Rated Output	1.0~2.0mV/V
Zero Balance	±2%F.S.
Non-linearity	0.10% F.S.
Hysteresis	0.05% F.S.
Non-repeatability	0.05% F.S.
Creep (30min)	0.05% F.S.
Temp Effect On output	0.05% F.S. / 10°C
Temp Effect On Zero	0.05% F.S. / 10°C
Response Frequency	10kHz
Impedance	350Ω
Insulation Resistance	>5000MΩ / 100VDC
Operating Temp. Range	-20~80°C
Working Voltage	5~10V
Safe Overload	150%
Maximum Overload	200%
Cable	Ø2 X 2m