

# Delta Transducers

**Model : ARI751B**



## Features & Application

Adopt stainless steel material, excellent accuracy, good long-term stability, repeatability, high reliability, Widely used in pressure testing machine, hopper, according to the material testing machine, belt said, etc. Various kinds of automation equipment.

## Mounting Dimension

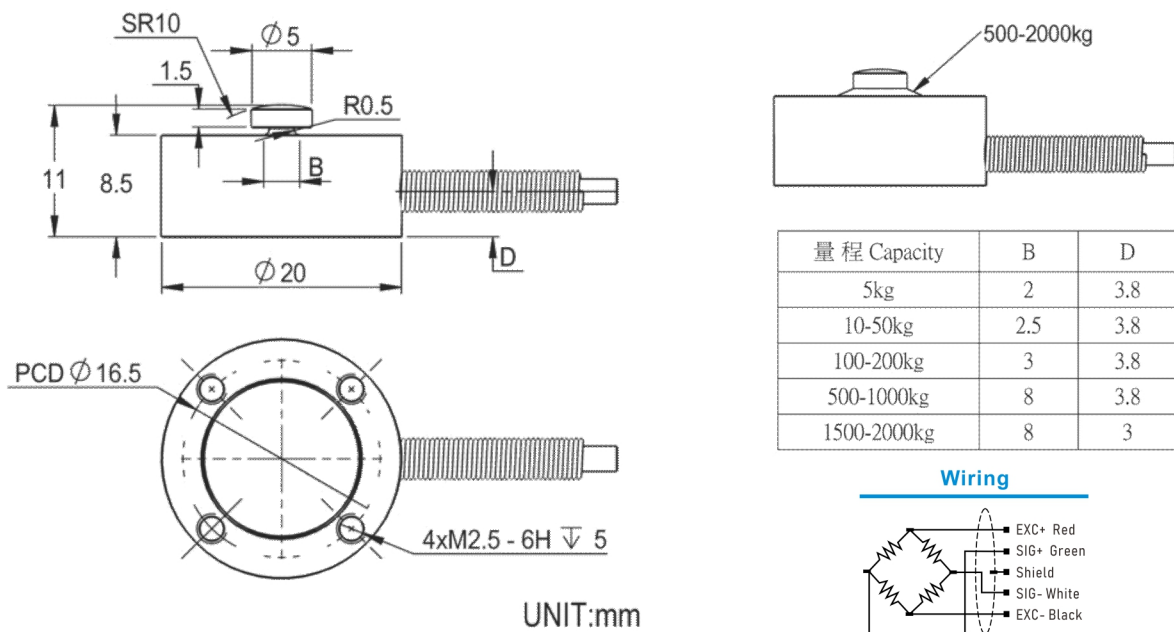

## Technical Parameters

Specifications	Technique
Rated load	5, 10, 20, 50, 100, 200, 500, 1000, 1500, 2000 kg
Rated output	1.0~2.0mV/V
Zero balance	±2.0%F.S.
Non-linearity	0.3% F.S.
Hysteresis	0.3% F.S.
Repeatability	0.1% F.S.
Creep (30min)	±0.05%F.S.
Temp.effect on output	±0.03%F.S. / 10°C
Temp.effect on zero	±0.03%F.S. / 10°C
Insulation resistance	≥5000MΩ / 100VDC
Impedance	1000Ω
Working voltage	5~10V
Operating temp range	-20~80°C
Safe overload	150%F.S.
Maximum overload	200%F.S.
Cable specifications	Φ3x2m